

Owners Manual

ShowerBuddy
SB6-22 & SB6-26



showerbuddy®

INTENDED USAGE:

The shower/commode chair is a medical device indicated for use by persons with limited mobility who are unable to stand, walk and/or seat independently. The device is specifically designed for individuals who require additional support and stability during washing, toileting and other hygienic activities. It is a class 1 medical device, which is intended to be used only as a seating option for toilet issues, showering and bathing. Its purpose is to help physically handicapped people during their hygienic activities. Any other use is prohibited.

INDICATIONS:

The device is specifically indicated for individuals who (because of the wide variety of possible health problems) are unable to stand and /or walk and so they need an assistance device to maintain some or all daily hygienic tasks.

CONTRADICTIONS:

This type of device must not be used by a disabled person alone. The user should always be accompanied by a caregiver or assistance person. The device is not recommended for persons with flaccid paralysis or other diseases that cause serious body control problems. Such persons require special wheelchairs designed for extra stability and support of the user's body. The need for this type of specialty wheelchair should be always estimated and indicated by a physician or a physical therapist.

WARNING – Included in this packaging and fitted to the chair are small parts, plastic wrap and polystyrene packing that could be dangerous to children under 5.

Keep children away from this device and do not let them play with any parts.



Be careful! Fingers or other body parts of a user and/or assistant can be trapped between the device's parts during folding, unfolding or adjusting of the device. Be extremely careful when adjusting the device. Observe the dimensions of gaps between the device's parts to avoid trapping your fingers or other body parts.

Contents Page

Components / Exploded Parts	3
Replacement / Parts List	4
Chair Assembly	5
Chair Operation	11
Cleaning and Maintenance	16
Safety Instructions	17
Warranty Information	20

Components / Exploded Parts

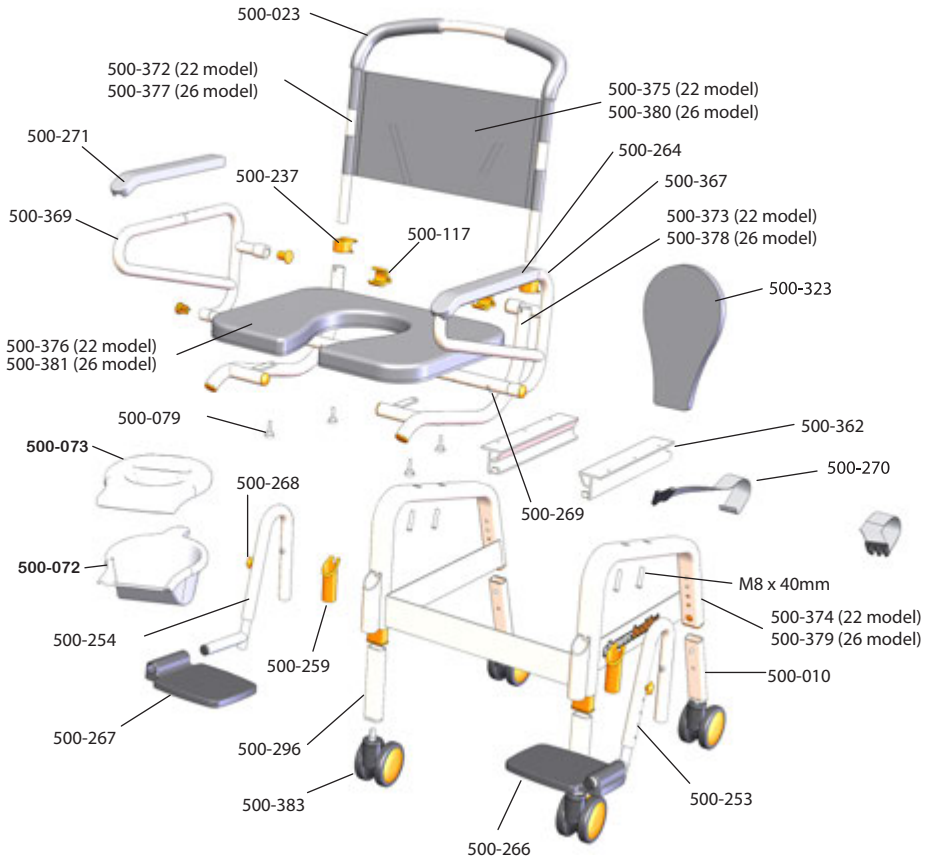

Replacement / Parts List

500-023	——	Foam Hand Grip	500-268	——	Footrest Adjust Knob
500-375 (22 model)	——	Sling Seat Back	500-253	——	LH Foot Support
500-380 (26 model)			500-254	——	RH Foot Support
500-117	——	Arm Lock	500-010	——	Rear 4" Caster Leg
500-237	——	Arm Lock Clip	500-267	——	RH Foot Tray
500-372 (22 model)	——	Back Rest Frame	500-296	——	Front 4" Caster Leg
500-377 (26 model)			500-073	——	Rear Caster
500-271	——	Arm Cushion RH	500-323	——	Seat Cushion Insert
500-367	——	LH Arm Assembly	500-005	——	Caster Leg Sleeve
500-369	——	RH Arm Assembly	500-266	——	LH Foot Tray
500-376 (22 model)	——	Seat Cushion	500-270	——	Safety harness
500-381 (26 model)	——	Seat Frame	500-072	——	Commode Bucket
500-373 (22 model)	——	Seat Frame	500-073	——	Commode Lid
500-378 (26 model)			500-259	——	Leg Tube
500-269	——	Push Pin			
500-001	——	Leg Frame			
M8 x 40mm	——	M8 Stainless Screw			
500-264	——	Arm Cushion LH			

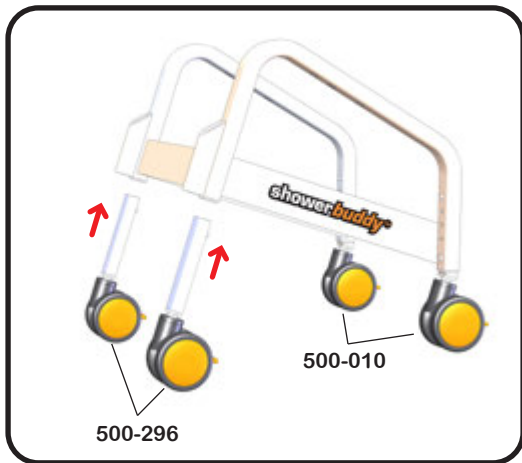

Assembly Instructions

Some factory assembly may have been carried out for you, which may differ slightly from the following instructions.

Step 1

Insert Caster Legs (part #500-296 Front and 500-010 rear) into Leg Frame (part #500-374 for 22 and 500-379 for 26).

Caster legs differ between front & rear.

Ensure the correct ones are used

Ensure all push pins are set at the same height location to ensure the wheeled base is level and does not rock when sitting on all 4 caster wheels.

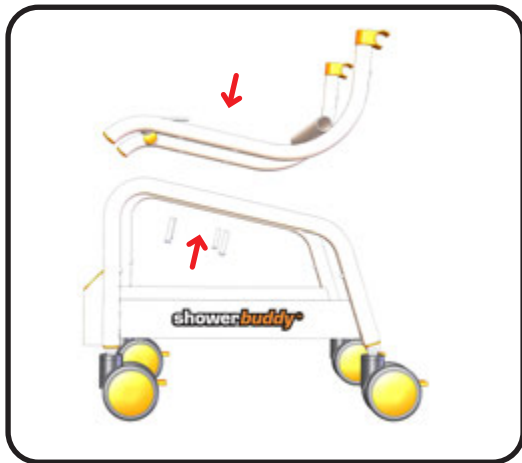

Step 2

Sit Seat Frame (part #500-373 for 22 and 500-378 for 26) on top of Leg Frame (part #500-374/379) and secure in position by screwing in 4 x hex screws supplied (M8 x 40mm).

Note: This part may come pre-assembled from the factory.

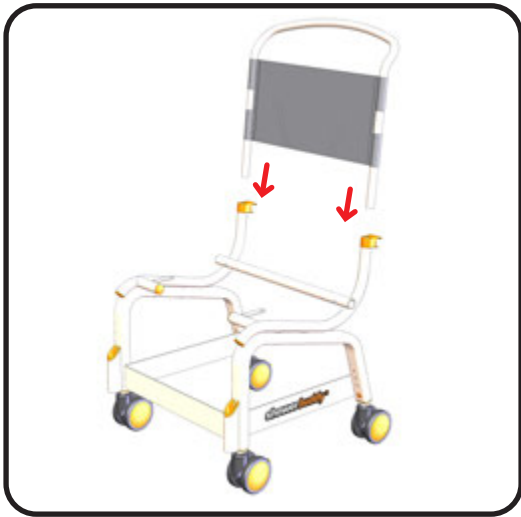

Step 3

Slide Back Rest Frame (part #500-372 for 22 and 377 for 26) down through Arm Clips (part #500-237) and into the Seat Frame (part #500-021). Make sure that push pins are fully depressed before inserting the back rest frame.

Push down until push pin comes out of the holes in the back of the frame.

Step 4

Fit Left Hand Arm (part #500-367) and Right Hand Arm (part #500-369) by positioning the axle (smaller diameter) part of the tube against the hollow tube across the rear of the Seat Frame (part #500-373/378) and sliding into this tube.

The Push Pin (part #500-269) will need to be pushed in (depressed) to allow the arms to be fully inserted into this tube.

Once fully inserted the Push Pin will “pop out” into the formed slot to lock the arm into position. This prevents the arm from being removed again without depressing the Push Pin.

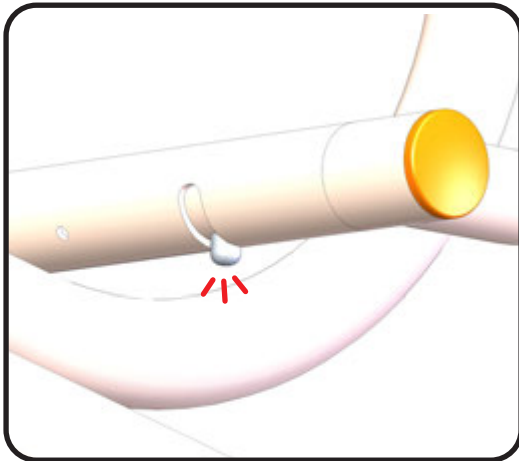
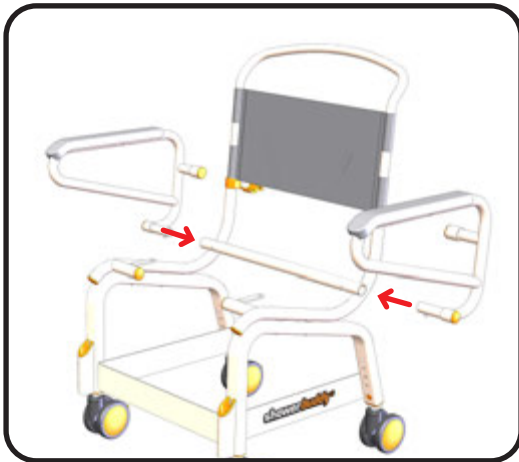

Step 5

Note: This part may come pre-assembled from the factory.

Fit Commode Cushion (part #500-376/381 for 22 & 26) by positioning onto the Seat Frame (part #500-373/378) and align the 4 fixing locations.

Fix down using 4 x Seat Fixing Knobs (part #500-079) and tighten.

The Cushion will have the Commode Bucket rails (part #500-362) pre-fitted at the factory.

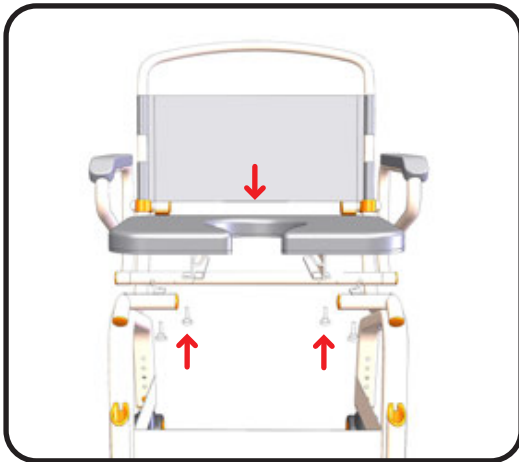

Step 6

The Footrest Assemblies will come pre-assembled from the factory.

To install these assemblies insert the Left and Right hand Footrest Support Tubes (parts #500-253 and #500-254 respectively) into the Seat Frame (part #500-021) as shown on the diagram.

Ensure the location pins are seated inside the location groove shown (part #500-259)

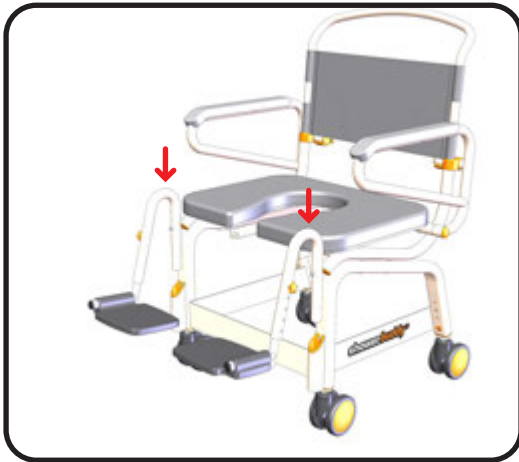

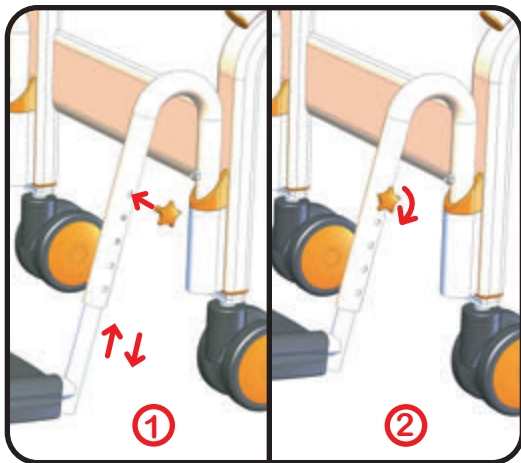

Adjust the Footrest height to suit the user as shown ensuring that the screw lock is fully tightened and the foot supports are level.

Note: The Footrest to Seat Cushion distance can be increased further, if required, by raising the seat height.

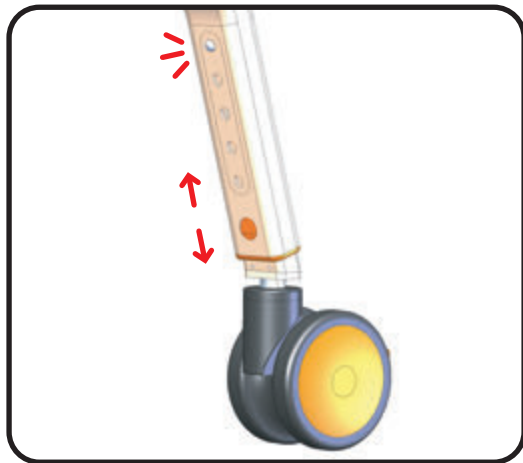

To adjust the Seat Height adjust the Caster Legs (part #500-296 front & 500-010 rear) by using the Push Pins in the legs and ensure that the push pins fully engage the height adjustment holes evenly.

Step 7



The Commode Bucket (part #500-072) can be pushed into position from the rear of the chair and is held in position by the Commode Bucket rails (part #500-362) pre-fitted to the cushion at the factory.

The Commode Bucket lid is for use after the bucket has been removed from the chair.

The chair is now fully assembled and ready for use.

Operation

Caster Wheels

The caster wheels can be locked and unlocked by depressing the foot brake pedal on each caster wheel. All caster wheels should be locked during the transfer of the user to and from the chair.

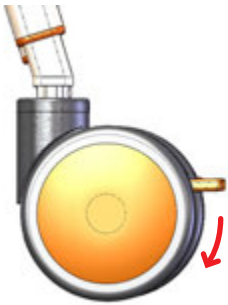

The caster wheels should be rotated outwards towards the front and rear of the chair to make the chair more stable during transfers.



Seat Height Adjustment

To raise or lower the seat height depress the push pin in the caster leg as shown and move the caster leg up or down to suit the user height requirement.

Ensure all push pins are set at the same height location to ensure the wheeled base is level and does not rock or feel unstable. The chair must sit on all 4 caster wheels.

WARNING

If you find a push pin is not fully engaging or “popping out” into position after use **DO NOT** use the chair. Consult your supplier for adjustment.

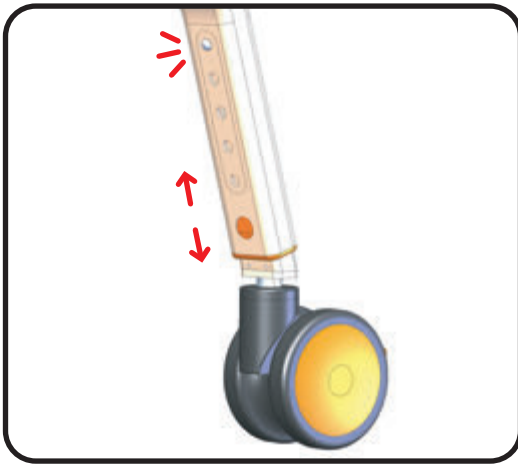

The chair may be adjusted to have a higher seat height at the front and lower at the back to suit user requirements. This can be accommodated by adjusting the front caster leg only to be extended further than the rear caster leg. Under no circumstances should there be more than 1-adjustment position difference between front and rear (approximately 20mm).

In every circumstance the chair must be adjusted with all caster wheels set to touch the ground at the same time otherwise the chair will rock and will not be stable. **DO NOT** use the chair unless all 4 caster wheels are firmly on the ground.

Footrest / Height Adjustment / Fold Away

The tray style footrests fitted to your chair are not designed to carry user weight. They are designed for a user to rest their feet.

WARNING - DO NOT STAND on the footrest as the chair may become unstable and tip forward causing injury to the user.

To raise or lower the footrests unscrew the locking knob in the footrest supports (parts #500-253 and part #500-254) and move the footrest supports up or down to suit the user height requirement.

Should the user be very tall and require additional seat cushion to footrest adjustment, raise the seat height (as detailed earlier) while having the footrest support at the lowest setting.

The footrests can be folded and swung away when not in use or during transfers.

1. Lift the footrest plate and fold it up until required to be lowered again.

2. Lift footrest assembly and rotate to swing the entire leg out and away should more room be required.

To remove completely simply lift away from the main seat assembly.

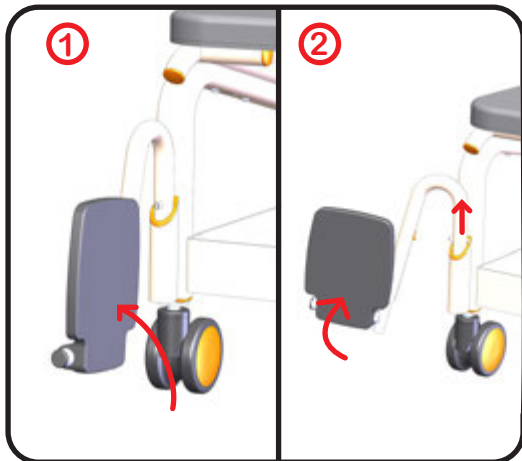
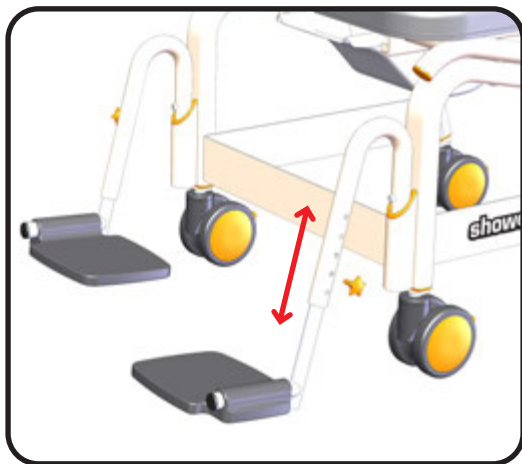

Arm Rests / Locking and Release Mechanism

You can easily swing the armrest up and out of the way or secure the armrest in the down position. To unlock the armrest slide the arm lock (part# 500-117) in towards the centre line of the chair back as shown, to allow the arm to be moved upwards and out of the locked position. To lock the armrests just push the armrest back down into the lowered position and slide the lock back to its original position. Ensure the slide lock is fully over the plastic clip.

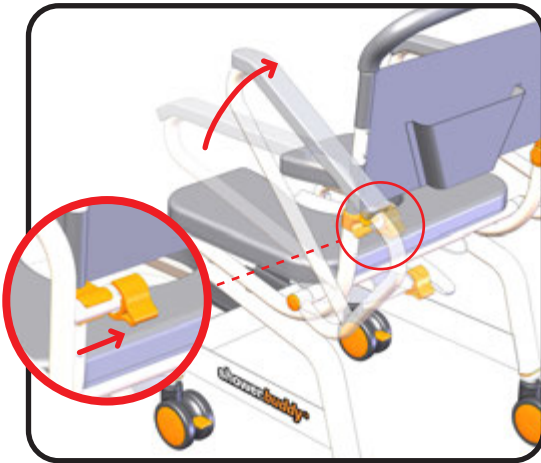

To fully remove an arm rest from the chair, depress the push pin (part #500-269) fully allowing the arm rest to be pulled outwards from the seat frame tube. To re-fit the arm, reverse this action.

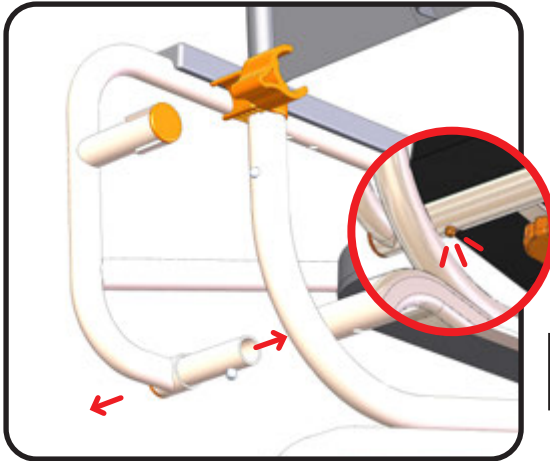

Be careful! Fingers or other body parts of a user and/or assistant can be trapped between the device's parts during folding, unfolding or adjusting of the device. Be extremely careful when adjusting the device. Observe the dimensions of gaps between the device's parts to avoid trapping your fingers or other body parts.

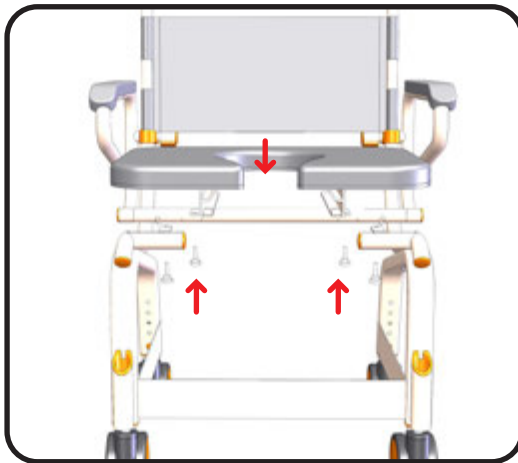

Seat Cushion

The seat cushion can be removed for cleaning by releasing the seat fixing screws (part #500-079) underneath the seat cushion.

Seat Cushion Insert (part #500-323) can be placed inside the hole to close off the seat cushion.

Storage is provided on the rear of the backrest

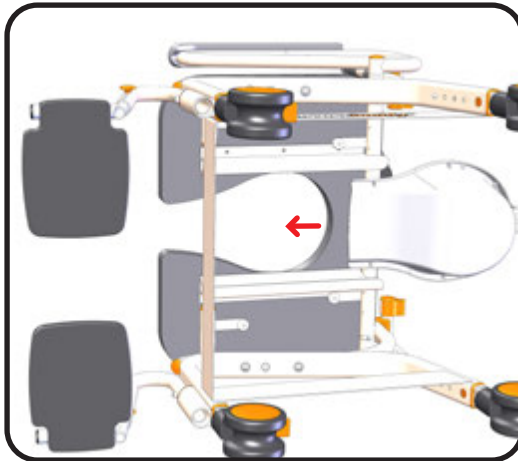
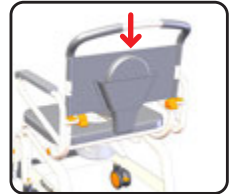
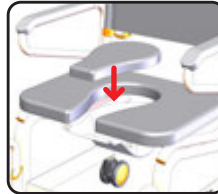

Commode Bucket & Splash Guard

Rails (part #500-362) hold the commode bucket (part #500-360) to the chair and are factory-fitted to the underside of the cushion. Slide the commode bucket in from the rear of the chair and locate the bucket into the rails. Push the bucket in until it stops against the connector end.

Once the user has transferred to the chair the splash guard can be fitted to the front of the cushion commode opening aperture. The splash guard is fitted by sliding it onto the holder clips fitted to the underside of the cushion at the front and each side of the commode opening. Alternatively (if the commode bucket is in place) the splash guard can be fitted by sliding it onto the front edges of the commode bucket

The commode cover should be used when transferring contents to the toilet to avoid spills.

Cleaning and Maintenance

It is recommended that your shower chair is serviced annually by your Dealer or an authorised, competent service agent. In addition:

1. Regularly inspect all parts of the chair for defects. Any defective part should be attended to promptly by an authorised service agent.
2. Clean the seat using a damp cloth and a mild cleanser. Always read the manufacturers instructions prior to applying the cleanser. When using Sodium Hypochlorite (Bleach) on the seat, a solution of 0.1% Sodium Hypochlorite should have no adverse effects on the cleaning of chairs. However, when using a solution of 1.0%, care should be taken to rinse the chairs thoroughly with clean water after application. Over a period of time bleaching may occur, but the integrity of the product will remain unaffected.
3. Dry off the shower chair after use.
4. Do not oil or grease any parts.
5. Keep the castors free from lime scale, soap residue and hair by cleaning after use in the shower.

Caring for stainless steel.

Stainless steel has excellent corrosion resistance, but it is not stain or rust proof. Regular maintenance will keep stainless steel clean and free of contaminants. In most applications stainless steel will not rust or stain even after many years of service, but when used in certain environments such as concentrated chlorine or other corrosive elements stainless steel requires proper care and maintenance. Do not leave stainless in contact with iron, steel or other metals.

1. Clean stainless steel frequently with soap and water. Any cleaner safe for glass is usually safe for stainless steel; apply with a cotton cloth.
2. Use a coating such as a good wax to help safeguard the stainless steel.
3. Remove discolouration or rust spots as soon as possible with a brass, silver or chrome cleaner. Irreversible pitting will develop under rust that remains on stainless steel for any period of time. Apply a mild cleaner such as Ajax or an equivalent with a wet cotton cloth. Rinse thoroughly and wipe dry. Do not use abrasives such as sandpaper or steel wool on stainless steel.
4. Do not clean with mineral acids or bleaches.
5. Do not store near any chlorine product.

Safety Instructions

Safety Warning!

Failure to comply with these safety instructions may result in injury or damage!

It is important that the user(s), and/or the caregivers of the user(s), learn how to safely operate the shower chair.

The following must be read before using the shower chair to ensure the safe operation.

The Owner(s) Manual must be read and understood before using the shower chair. If you don't understand any parts of the Owner(s) Manual, clarification should be sought prior to using the product.

For further clarification of any part of the Owner(s) Manual call your local dealer

Transfers to and from the shower chair can be dangerous. Consult a Physical or Occupational Therapist to ensure safe and reliable transfer techniques is practiced.

Individuals who have not learned these skills must have assistance during transfers.

Do not use the shower chair for any application outside of the manufacturers intended use, this can result in damage to the shower chair and components. Not complying with the manufacturer's instructions can result in injury to the user(s) or caregiver. The manufacturer or dealer will not be held responsible for any injury or damage resulting from the misuse or inappropriate operation of the Showerbuddy shower chair.

If any part of the shower chair requires maintenance please don't hesitate to contact your dealer. Any problems that could affect the safe operation of the chair **MUST** be attended to immediately. The **MAXIMUM** user weight for this shower chair is: 440lbs (200kg) for 22 and 26 models

ALWAYS ensure that your shower chair is capable of manoeuvring over surfaces that will be encountered, prior to operating the shower chair with any user(s). This chair is only intended for use indoors, on flat surfaces, without thresholds, steps, curbs or obstacles.

ALWAYS lock the castor wheels when the chair is stationary. To do this step-on the lever that activates the wheel locks.

DO NOT STAND or step on the footrest, as the chair will tip forward possibly causing injury to the User. The footrests are not load bearing and are not intended or designed as a step.

DO NOT lean forward or sideways out of the shower chair as this may cause the chair to tip.

DO NOT wheel the shower chair down an incline without a caregiver who can control the chair during its descent.

DO NOT use the shower chair castor wheel locks as brakes when travelling down inclines.

DO NOT position the shower chair sideways on a slope as this could cause it to tip.

Important!

Although every effort has been made by the manufacturer to ensure the stability of the shower chairs during use, it is important to recognize that the most dangerous part of using any shower chair is the transfer. If you are unsure of how to perform transfers in a way that can be performed safely, then contact a Physical or Occupational Therapist who is familiar with transfer techniques and options.

The wheel locks on the castors are designed to prevent the castor wheels from rotating when the shower chair is stationary. These **DO NOT** and **CANNOT** prevent the wheels from sliding if the floor is slippery. A slippery floor can be caused by dust, water, soap or any substance that doesn't allow the tires (tyres) to grip. Transfers should never be attempted with the shower chair positioned on slippery surfaces since the wheel locks can only prevent the wheels from rotating. It is recommended that transfers be performed on clean, dry non slippery surfaces. When transferring onto a Shower Chair always lock all castors in their outward position (front castors positioned in the forward and out position / rear castors positioned to the rearward and out position) for maximum chair stability.

Never use the foot rest to assist with transfers. This could cause the chair to tip forward. The footrest should be folded away during transfers to provide unobstructed access to the shower chair.

DO NOT stand on the footrest as this is designed to provide support for the user's feet while seated and not to act as a load bearing component when the user mounts or alights from the chair. Standing on the footrests could cause the chair to tip forward.

The fasteners – Knobs, nuts, bolts, washers – should be checked periodically to ensure that they are securely fastened. Your dealer should be called to check the fasteners and other components at least once per year.

Important!

ADJUSTMENTS SHOULD NEVER BE ATTEMPTED WITH THE USER(S) IN THE CHAIR!

Your authorized dealer can help you with any adjustments you may want to make on your shower chair or can provide clarification on any of the information contained herein.

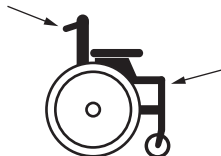

How to lift the chair

Lift the wheelchair up using the push handles and the front upper corners of the wheelchair frame, where the footrests are placed.

WARNING! It is not allowed to lift the wheelchair up by gripping the footrests or armrests! We recommend to detach footrests before lifting the chair

Warranty Information

2 Year Limited Warranty on Frame

Your shower chair frame is covered by limited warranty for two years on the frame, 6 months on the caster wheels and cushion and 1 year on all other parts from the date of purchase by the user. Proof of purchase from an authorised Dealer is required for any claim.

This warranty covers any defects in materials and workmanship on all shower chairs except those listed in the Warranty Exclusion below:

Warranty Exclusions

- Product or parts failure from normal wear and tear
- Damage caused by failure to adhere to the Owner's Manual
- Damage from improper assembly, use or repair
- Any chair not purchased from an authorised Dealer

Limitations

- The warranty is VOID if the original serial number tag is removed or altered
- The warranty is VOID if the shower chair sustains damage from unnatural causes
- The warranty is VOID if the weight limit of 440lbs (200kg) for 22 and 26 models
- The warranty is VOID if the shower chair has been subjected to neglect, improper maintenance, storage, cleaning or operation as defined in the Owner's Manual
- The warranty is VOID if the shower chair is modified in any way
- This warranty applies to the original purchaser only, from the date of the purchase.

Your Responsibilities

- If your shower chair requires warranty service, please contact the dealer from which you purchased the shower chair.

Our Responsibilities

- The manufacturers sole responsibility is to repair or replace, at our discretion, the warranty covered components of the shower chair. This is the exclusive remedy for consequential or incidental damages.
- Upon pre-approval, the manufacturer may provide exchange services for Warranty returns.

- Under this program, a refurbished shower chair may be shipped after the return of the defective unit. The exchange shower chair may contain used parts that meet the manufacturers quality standards. This program is provided at the sole discretion of the manufacturer. The original warranty term will not be extended due to such a shower chair exchange and a return shower chair will become the property of the manufacturer.

For all USA & Canada Warranties

You can fax or email us

Showerbuddy LLC
12405 Montague Street
Pacoima, CA 91331
U.S.A

Email: info@myshowerbuddy.com Phone: (877) 7MY-
BUDDY (769-2833) Fax: (888) 312-3645

For all Other Worldwide Warranties

Email: admin@shower-buddy.com
Showerbuddy NZ Ltd
Phone: (+64) 21 449-806

Reuse

This medical device can be reused by another owner if the original owner of the product doesn't need it anymore. Before reuse the device must be carefully inspected by authorized technical staff.

Following elements should be checked:

- rigidity of the structure,
- tightness of bolts and nuts,
- condition of plastic elements,
- condition of wheels and ball bearings,
- efficiency and condition of brakes.

If any of above elements are torn or broken, they should be replaced with new parts. It is specially recommended to install new wheels, seat and backrest for every new user of the device. All loose bolts and nuts must be tightened. The product must be precisely cleaned and disinfected. Every new owner must receive the device with this user's manual attached.

WARNING! It is forbidden to reuse the device if the main frame is bent or broken.

Disposal of Your device

The device should not be deposited with normal garbage. Your shower chair must be disposed according to applicable local and national statutory regulations. Contact your local waste disposal agency or authorized dealer of rehab equipment for information on proper disposal of the chair, packaging, metal frame components, plastic components and other materials.

International Office

Showerbuddy NZ Ltd

Email: admin@shower-buddy.com

Phone: (+64) 21 449-806

www.shower-buddy.com

USA & Canada Enquires

Showerbuddy LLC

12405 Montague Street

Pacoima, CA 91331

U.S.A

Email: info@myshowerbuddy.com

Phone: (877) 7MY-BUDDY (769-2833)

Fax: (888) 312-3645

www.myshowerbuddy.com

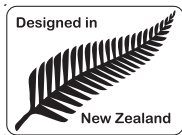

All ShowerBuddy products are CE, TUV, ISO9001 and TGA certified.
complying to AS/NZS 3973:2009 and AS4069-2013

Independent Laboratory Testing Carried out by NovitaTech Laboratories, South Australia, February 2013.

Copyright © 2014 by Showerbuddy NZ Ltd

All rights reserved

