

Reorders

To order additional/replacement parts and accessories for your Wireless Sensor System, contact your AllMed representative.

Wireless Sensor System Parts and Accessories

<i>Item Name</i>	<i>Order/Part Number</i>
Wireless Sensor System Patient Unit	2130
Wireless Sensor System Remote Unit	2131
Bed Sensor pad 10" x 30" (6 month guarantee)	77066
Chair Sensor Pad 10" x 15" (6 month guarantee)	77061
Nurse Call Connector with Y adapter	2035
Magnetic Rail Bracket	2208
12V AC Power cord (for use with Patient Unit and Remote Unit)	2134
Mesh Alarm Mounting Bag (3/pk)	75303
Batteries, AAA (20/pk)	74878
Batteries, C (2/pk)	5299



Wireless Sensor System

Operator's Manual

#2130 Patient Unit

#2131 Remote Unit

AllMed, Inc.
297 High Street
Dedham, MA, 02026
www.AllMed.com

FCC Warning

NOTES:

Changes or modifications to this system not expressly approved by the party responsible for compliance could void the user's authority to operate the equipment.

Radio Frequency Interference

This equipment has been tested and found to comply with the limits for a Class B digital device, pursuant to Part 15 of the FCC Rules. These limits are designed to provide reasonable protection against harmful interference in a residential installation. This equipment generates, uses and can radiate radio frequency energy and, if not installed and used in accordance with the instructions, may cause harmful interference to radio communications, including some pager signals.

However, there is no guarantee that interference will not occur in a particular installation. If this equipment does cause harmful interference to radio or television reception which can be determined by turning the equipment off and on, the user is encouraged to try to correct the interference by one or more of the following measures.

- Increase the separation between the equipment and receiver.
- Connect the equipment into an outlet on a circuit different from that on which the receiver is needed.
- Contact the dealer or experienced radio/TV technician for further assistance.

Limited Warranty

The manufacturer guarantees the quality and workmanship of the Wireless Sensor System Patient Unit and Remote Unit for a period of one (1) year from date of purchase. This warranty is in force provided there is no evidence of misuse or improper installation.

Under the conditions of this warranty, the manufacturer agrees to repair and return any defective or inoperative Wireless Sensor System units, components, or parts without charge. Batteries are not included in this warranty.

Units, components, or parts that are determined not to be covered by this warranty because of time, abuse/misuse, or improper installation, will be repaired or replaced by the manufacturer on an established cost repair basis.

THE MANUFACTURER DOES NOT CLAIM THAT THE WIRELESS SENSOR SYSTEM WILL PREVENT BED AND CHAIR-RELATED FALLS WITHOUT FALL. IT DOES CLAIM THAT, WITH A COORDINATED EFFORT FROM THE INSTITUTION NURSING STAFF AND AN ACCEPTABLE FALL PREVENTION PROGRAM, THE WIRELESS SENSOR SYSTEM CAN HELP TO REDUCE THE NUMBER OF FALLS THAT OCCUR WITHIN AN INSTITUTION.

All questions, requests, or inquiries should be directed to:

AllMed, Inc.

297 High Street

Dedham, MA, 02026

www.AllMed.com

Table of Contents

Introduction	5
Parts List.....	6
Installation	7
Installing the Batteries.....	7
Mounting the Alarm Units	7
Connecting the Power Cords (Optional).....	9
Attaching Sensor Cables.....	10
Connecting the Nurse Call Adapter (Optional).....	11
Programming	12
Overview	12
Programming Options	14
Assigning Sensor Types.....	15
Assigning ID Codes	15
Alarm Volume	17
Hold Length	18
Activation Delay	19
Alarm Length	20
Operation	21
Overview	21
System Modes.....	22
Turning Power On/Off	23
Setting Alarm Volume	24
Using the Hold Function.....	24
Extending Hold Mode	24
Cancelling Hold Mode	25
Resetting the System.....	25
Silencing the Remote Unit (Semi-Reset mode)	25

Testing the System	26
Testing Patient and Remote Units	26
Testing the Nurse Call Function	26
Warnings and Cautions	27
Care and Maintenance	28
Cleaning Units	28
Replacing Batteries	28
Troubleshooting	29
Product Specifications	33
Warranty Information	34
Reorders	36

Wireless Sensor System Product Specifications

Dimensions of Patient Unit:	5.3 x 3.7 x 1.2 in. (13.5 x 9.5 x 3 cm)
Dimensions of Remote Unit	6.3 x 4.5 x 1.9 in. (16 x 11.5 x 5 cm)
Weight without batteries (Patient Unit)	8.8 oz. (206 g)
Weight without batteries (Remote Unit)	13.9 oz. (322.8 g)
Alarm tone frequency (Patient Unit)	1.3KHz
Alarm tone frequency (Remote Unit)	Di - 625Hz / Da - 500Hz
Functional Temperature Range	-4°F to 122°F (-20°C to 50°C)
Functional Humidity Range	85% and below
Functional Signal Transmission Range	50 - 100 feet Range can be affected by environmental conditions, such as building structure.
Transmission Frequency	433.92 MHz
Expected Battery Life (based on usage of 12 hrs/day with alarm sounding 1 hr/day)	Patient Unit: 66 days Remote Unit: 49 days
Functional Battery Range (Remote Unit)	Battery: 3.1 - 6.0 VDC AC Input: 9 - 15 VAC Low Battery Indicator becomes active once battery voltage falls below 4.0 VDC
Functional Battery Range (Patient Unit)	Battery: 3.1 - 4.5 VDC AC Input: 9 - 15 VAC Low Battery Indicator becomes active once battery voltage falls below 3.1 VDC

Alarm sounds continuously.

- Ensure Patient Unit is set to the correct Sensor Type (Bed/Chair, Floor, or Optical).
- **Turn power off before changing sensor setting.**
- Ensure Bed/Chair sensor pad is placed properly (see sensor pad manufacturer's recommendations for placement).
- Check cable connection between sensor pad and Patient Unit. Make sure the cord is securely in the jack. When secured, the cord should click into place.
- Ensure sensor pad is not bent or damaged and the cord is intact.
- Check for objects that may be putting pressure on the sensor pad.
- If using Optical sensor, check for the following:
 - On the sensor, confirm that the red LED is on. If the LED is off, an object is blocking the beam or the sensor is not functioning.
 - Confirm that the Optical sensor beam is positioned parallel to bed frame.
 - Ensure that Optical sensor is mounted so that no objects are within 8' of the front of the sensor.
- Surface may not be suitable for Bed/Chair sensors (for example, pressure reducing mattress, mattress overlay).

Introduction

The Wireless Sensor System consists of the following components:

- Patient Unit (Part #2130)
- Remote Unit (Part #2131)
- Sensors (Bed, Chair, Floor, or Optical)
- Nurse Call Connector (optional)

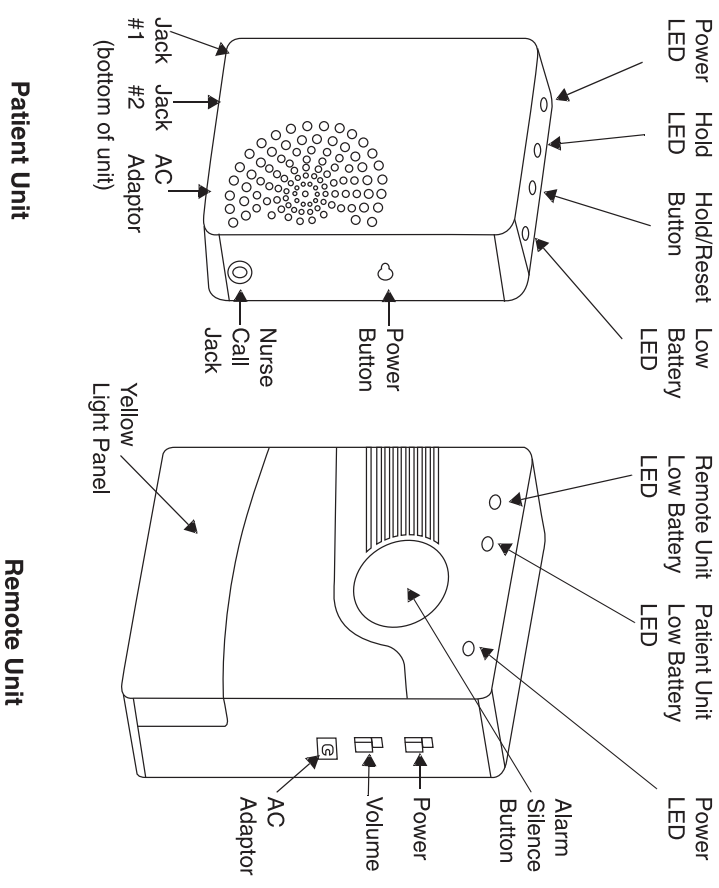

Parts List

Patient Unit

The following items are included with the Patient Unit:

- Wall Mounting Bracket
- (2) Plastic Wall Anchors
- (2) 1" screws
- Double-sided tape
- (3) AAA batteries
- Instruction Manual

Remote Unit

The following items are included with the Remote Unit:

- Wall Mounting Bracket
- (2) Plastic Wall Anchors
- (2) 1" screws
- Double-sided tape
- (4) C batteries
- Instruction Manual

Optional Accessories

- Nurse Call Connector with Y Adapter
 - Mesh Alarm Mounting Bag
 - Bed Sensor Pads
 - Chair Sensor Pads
 - Floor Sensor Pads
 - Optical Sensors
 - Magnetic Bed Rail Clamp
 - 12V 300 mA AC Adaptor (for use with Patient Unit and Remote Unit)
- See back cover for part numbers and reordering information.

I have to replace the batteries too often.

- Ensure that alkaline batteries are not mixed with rechargeable batteries.
- Confirm that rechargeable battery types are identical (for example, all Ni-Cd or all Lithium Ion).
- Rechargeable batteries have a limited life span. Refer to battery manufacturer for suggested life.
- Optical sensors cannot be used with batteries. Patient Unit must use AC Adaptor when using Optical sensor.

Remote Unit is not functioning.

- Confirm there is power to the unit.
- Check Low Battery indicators on Remote Unit. Low Battery LED will flash continuously and unit will sound a tone every 30 seconds when battery is low. Replace batteries immediately.
- Confirm ID Code for Patient Unit and Remote Unit are identical.
- Remote unit did not properly reset. Power down Remote Unit to reset. Power on unit and retest.
- Patient Unit and Remote Unit cannot be more than 100 feet apart in an open area. This distance can be greatly reduced by building structure. Move units closer together and retest.

The alarm beeps intermittently (approximately once every 30 seconds).

- Check Low Battery indicators on Patient Unit and Remote Unit. Low Battery LED will flash continuously and unit will sound a tone every 30 seconds when battery is low. Replace batteries immediately.

The alarm sounded and patient wasn't out of her bed/chair.

- Ensure Bed/Chair sensor pad is placed properly (see sensor pad manufacturer's recommendations for placement).
- Check cable connection between sensor pad and Patient Unit. Make sure the cord is securely in the jack. When secured, the cord should click into place.
- Ensure that the Activation Delay is not set too low for the patient's level of activity. False alarms can be caused by fidgety patients or using the sensor pad on a very soft cushion or mattress. If necessary, increase the Activation Delay and retest.
- Confirm that patient did not get up and return to bed once alarm activated.
- If using Optical sensor, check for the following:
 - On the sensor, confirm that the red LED is on. If the LED is off, an object is blocking the beam or the sensor is not functioning.
 - Confirm that the Optical sensor beam is positioned parallel to bed frame.
 - Ensure that Optical sensor is mounted so that no objects are within 8' of the front of the sensor.
- **Turn power off before changing sensor setting.**

I reset the Patient Unit, but the Remote Unit didn't automatically reset.

- On the Patient Unit, press the Hold/Reset button for 1.5 seconds.
- Power off both the Patient and Remote Unit.
- Patient Unit and Remote Unit may be closer than 3 feet. If so, move units farther apart.

I replaced the batteries and now the unit will not turn back on.

- Remove batteries from unit and wait approximately ten minutes (for internal reset).
- Re-install same batteries.
- See Battery Replacement Note (Page 28).

Installation

Installing the Batteries

1. Loosen screw at bottom of unit.
2. Remove back panel.
3. For the Patient Unit, insert (3) AAA batteries (included with unit). For the Remote Unit, insert (4) C batteries (included with unit).
4. Replace back panel and tighten screw.

NOTES:

- When installing batteries, do not mix alkaline batteries with rechargeable batteries, or mix different types of rechargeable batteries (for example, Lithium Ion and Ni-Cd).
- If the unit is running on AC power and batteries are also installed, the system will automatically switch from AC to battery power in the event of power loss.
- If using rechargeable batteries, please be aware that the units will not recharge the batteries when operating on AC power.

Mounting the Alarm Units

Patient Unit

When deciding where to place the Patient Unit, remember the following:

- Locate unit out of patient's reach.
- Secure excess cords for patient/staff safety.
- Mount unit so LED indicators are visible to staff.
- Patient Unit and Remote Unit must be at least 3 feet apart.
- Patient Unit and Remote Unit must be less than 100 feet apart. External factors, such as building structure, can affect the range of the units.

NOTE: Before mounting the Patient and Remote Units, test the system to ensure the units can communicate. See *Testing the System* for more information.

Turn power off before changing sensor setting.

Use the Wall Mounting Bracket (included) and the following procedure to attach the Patient Unit to a wall or other surface:

1. Attach mounting bracket to wall using screws (recommended) or double-sided tape.
2. Slide Patient Unit onto mounting bracket.

Using the Magnetic Bed Rail Clamp

When used with Optical sensor and magnetic bed rail clamp, mount the Patient Unit by placing the metal strip on the back of the Patient Unit onto the magnet in the bed rail clamp.

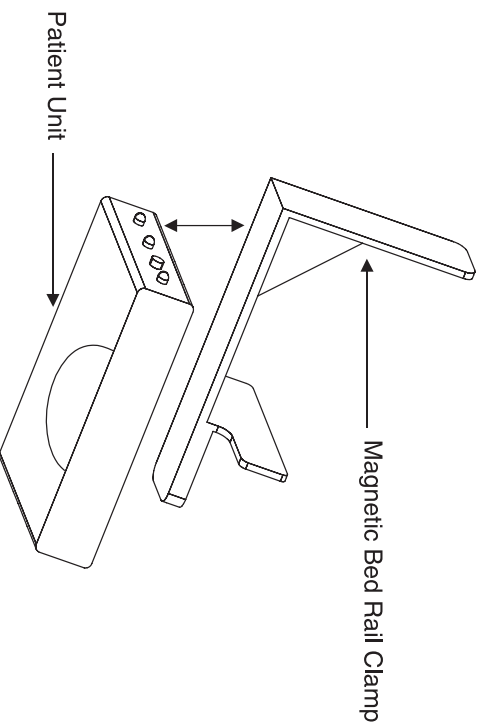

Troubleshooting

Patient got out of bed/chair and alarm did not sound.

- Confirm there is power to the unit.
- Check batteries and replace if necessary.
- Check whether Patient Unit alarm volume is set to Silent.
- Ensure sensor pad is not bent or damaged and cord is intact.
- Check for objects that may be putting pressure on the sensor pad.
- Confirm ID Code for Patient Unit and Remote Unit are identical.
- Ensure Bed/Chair sensor pad is placed properly (see sensor pad manufacturer's recommendations for placement).
- Confirm the Bed/Chair sensor is securely connected to Jack #1 on the Patient Unit. Bed/Chair sensor pad will not function if connected to Jack #2.
- **Turn power off before changing sensor setting.**

Patient stepped/fell on floor mat or interrupted optical beam and alarm did not sound.

- Confirm there is power to the unit.
- Check batteries and replace if necessary.
- Check whether Patient Unit alarm volume is set to Silent.
- Ensure sensor pad is not bent or damaged and cord is intact.
- Check for objects that may be putting pressure on the sensor pad.
- Confirm ID Code for Patient Unit and Remote Unit are identical.
- If using Optical sensor, check for the following:
 - On the sensor, confirm that the red LED is on. If the LED is off, an object is blocking the beam or the sensor is not functioning.
 - Confirm that the Optical sensor beam is positioned parallel to bed frame.
 - Ensure that Optical sensor is mounted so that no objects are within 8' of the front of the sensor.

Care and Maintenance

Cleaning Units

The Patient Unit and Remote Unit may be cleaned with a damp cloth or sponge using mild disinfectants. Never use alcohol, acidic, or harsh petroleum-based cleaners.

Replacing the Batteries

When the batteries within the units need to be replaced, the Low Battery LED lights up and the unit will beep intermittently (approximately every 30 seconds). When the Patient Unit's batteries are low, the Remote Unit will light up a separate Low Battery LED and also beep intermittently. Whenever a Low Battery warning occurs, replace the batteries as soon as possible.

To replace the batteries, do the following:

1. Turn off power to unit.
2. Loosen the screw at the bottom of unit.
3. Remove back panel.
4. For the Patient Unit, insert (3) AAA batteries. For the Remote Unit, insert (4) C batteries.
5. Replace back panel and tighten screw.

NOTE: When replacing batteries, power to units must be turned off before removal of batteries

When installing batteries, do not mix alkaline batteries with rechargeable batteries, or mix different types of rechargeable batteries (for example, Ni-Cd and Lithium Ion).

If using rechargeable batteries, please be aware that the units will not recharge the batteries when operating on AC power.

Using the Mesh Alarm Mounting Bag (Optional)

You can also use the Mesh Alarm Mounting Bag (available separately) to attach the Patient Unit to a bed rail, chair, or other area:

1. Place Patient Unit (with sensor cable attached) into the Alarm Mounting Bag.
2. Pull sensor cable so it runs outside of the bag and close the zipper.
3. Loop the Mounting Bag Straps around the desired object (bed rail, chair, etc.) and attach the straps to the closures on the rear of the bag.

Remote Unit

When deciding where to place the Remote Unit, remember the following:

- Locate unit out of patient's reach.
- Secure excess cords for patient/staff safety.
- Mount unit so LED indicators are visible to staff.
- Patient Unit and Remote Unit must be at least 3 feet apart.
- Patient Unit and Remote Unit must be less than 100 feet apart. External factors, such as building structure, can affect the range of the units.
- Mount unit so Alarm Silence button can be reached by staff.

You can mount the Remote Unit one of the following ways:

- To attach the Remote Unit to a metal surface (for example, a metal door frame), place the back of the Remote Unit onto the metal surface. The magnets within the back of the Remote Unit will affix the unit in place.
- To mount the Remote Unit to a non-metal surface, use the mounting bracket (included) and the following procedure to attach the unit to a wall or other surface:
 1. Attach mounting bracket to wall using screws (recommended) or double-sided tape.
 2. Slide Remote Unit onto mounting bracket.

Connecting Power Cords (Optional)

To connect AC Adaptor power cords (available separately) to the Patient Unit and Remote Unit, do the following:

1. Connect the power cord to the AC Adaptor jack on the unit.
2. Plug the power cord into an electrical outlet.
3. Secure any excess cord length for patient/staff safety.

Attaching Sensor Cables

Before attaching sensor cables, make sure that the Patient Unit is set to the appropriate sensor type. For more information on programming sensor types, see the *Programming* section of this manual.

IMPORTANT: Attach Bed/Chair sensor pads to Jack # 1 **only**. The system will not function if Bed/Chair sensor pads are attached to Jack # 2. Floor and Optical sensors can use either jack.

When using Bed/Chair sensors, you can only attach one Bed/Chair sensor to the Patient Unit. You cannot attach a second Bed/Chair sensor or combine a Bed/Chair sensor with Floor or Optical sensors.

When using Floor or Optical sensors, you can attach 2 sensors to the Patient Unit. You can connect 2 Floor sensors, 2 Optical sensors, or one of each.

1. Connect the cable from the sensor (Bed, Chair, Floor, or Optical) to the jack on the bottom of the Patient Unit.

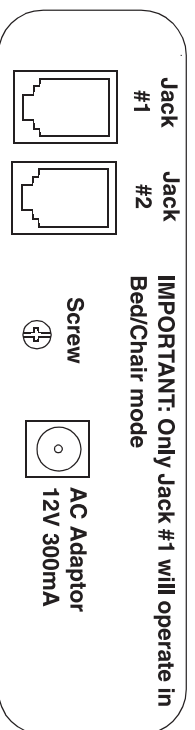

Patient Unit - Bottom View

2. Ensure the cable is connected securely in the jack.

10

6. Create an alarm by doing one of the following:
 - a. Bed/Chair/Floor sensor pads - put pressure on the pad for approximately 3 seconds and then release the pressure.
 - b. Optical - break the beam by placing an object in front of the sensor.
7. Wait 5 seconds and then confirm that the Nurse Call indicator is activated.
8. Reset the Nurse Call system.
9. Reset the Patient Unit.
10. Power off both the Patient and Remote Units.

Warnings/Cautions

- Use of this product by persons fitted with an implanted device, such as a pacemaker or defibrillator, may be potentially dangerous. Do not place magnet within 12" of implanted device. Refer to manufacturer of implanted device for more detailed instructions.
- Do not immerse the Patient Unit or Remote Unit in any liquid.
- Secure any loose cords to ensure patient/staff safety (for example, make sure all cords are safely away from the moving parts of a hospital bed).

27

Testing the System

It is recommended that you test the system before each use. To test the Wireless Sensor System, do the following:

1. Power on both the Patient and Remote Units.
2. Connect the appropriate sensor to the Patient Unit.
NOTE: Ensure that Patient Unit is programmed with the correct sensor type. For more information, refer to the *Programming* section of this manual.
3. Create an alarm by doing one of the following:
 - a. Bed/Chair/Floor sensor pads - put pressure on the pad for approximately 3 seconds and then release the pressure.
 - b. Optical - break the beam by placing an object in front of the sensor.
4. Confirm that the Remote Unit sounds the alarm.
5. Reset the Patient Unit and confirm that Remote Unit also resets.
6. Power off both the Patient and Remote Units.

Testing the Nurse Call Function

When using the Nurse Call function of the Wireless Sensor System, it is recommended that you test the system before each use to ensure that all components are functioning correctly. To test the Nurse Call function, do the following:

1. Connect the Nurse Call Y Adapter into the Nurse Call wall jack at the patient bedside.
2. Plug the patient's Nurse Call cord into one of the jacks on the Nurse Call Y Adapter.
3. Plug the 8' Nurse Call Connector cord into the other jack on the Nurse Call Y Adapter and to the Nurse Call Jack on the Patient Unit.
4. Power on both the Patient and Remote Units.
5. Connect a sensor to the Patient Unit.

Connecting the Nurse Call Adapter (Optional)

To connect the Wireless Sensor System to your existing Nurse Call system, you must purchase the Nurse Call Connector, which includes an 8' Nurse Call Connector cord and the Nurse Call Y Adapter.

When the alarm is activated, the system will wait 5 seconds (to allow for reset of the system) and then sends a signal to the Nurse Call system.

To connect the Wireless Sensor System to your existing Nurse Call system, use the following procedure:

1. Connect the Nurse Call Y Adapter into the Nurse Call wall jack at the patient bedside.
2. Plug the patient's Nurse Call cord into one of the jacks on the Nurse Call Y Adapter.
3. Plug the 8' Nurse Call Connector cord into the other jack on the Nurse Call Y Adapter and to the Nurse Call Jack on the Patient Unit.

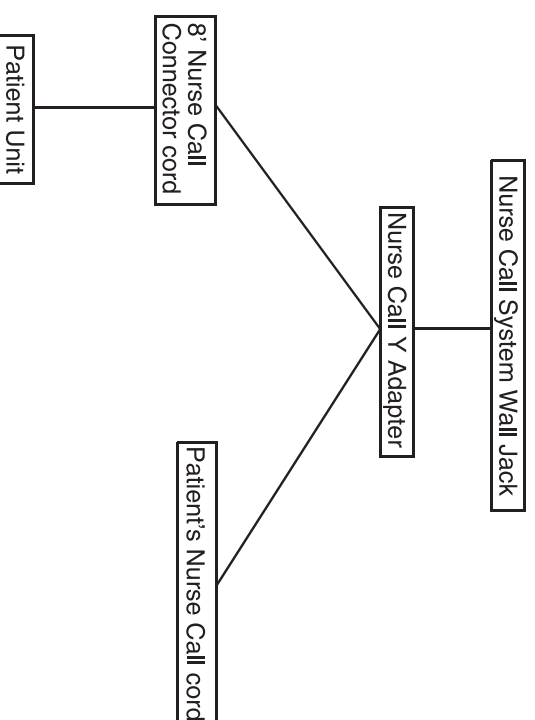

Programming

Overview

You can program the various functions of the Wireless Sensor System by configuring the DIP panels on the Patient Unit and Remote Unit. To access the DIP Panel, you must first remove the back cover of the unit. To remove the back cover, loosen the screw at the bottom of the unit. The DIP Panel is located on the circuit board as shown in the following figures:

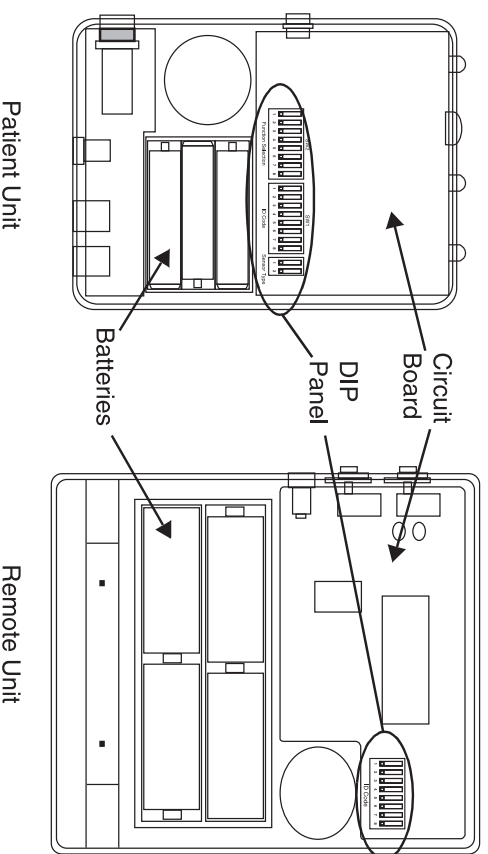

Canceling Hold Mode

When the unit is in Hold status, you can cancel Hold mode by momentarily pressing the Power button on the Patient Unit. Pressing the Power button returns the unit to Monitor mode. When Hold mode is cancelled, unit will beep twice and yellow LED will stop flashing.

Resetting the System

Bed/Chair Sensors

When using Bed/Chair sensors, there are two ways to reset the system:

- When weight is reapplied to the sensor pad.
- When the reset button is pressed on the Patient Unit.

When the Patient Unit is reset, the unit beeps twice and sends a signal to reset the Remote Unit.

Floor/Optical Sensors

When using Floor or Optical sensors, the system can be reset only by pressing the Hold/Reset button on the Patient Unit.

When the Patient Unit is reset, the unit beeps twice and sends a signal to reset the Remote Unit.

Silencing the Remote Unit (Semi-Reset mode)

You can silence the Remote Unit by pressing the Alarm Silence button (the large round button in the center of the unit). The Remote Unit enters Semi-Reset mode. If the system has not been fully reset within 5 minutes, the Remote Unit will resume alarming. You can fully reset the system by reapplying weight to the sensor pad (Bed/Chair sensors) or by pressing the Hold/Reset button on the Patient Unit.

Setting the Alarm Volume

Patient Unit

The Patient Unit has 3 available Alarm Volume settings: Low (90 dB), High (100 dB), and Silent. To set the Alarm Volume for the Patient Unit, refer to the *Programming* section of this manual.

Remote Unit

On the side of the unit, select LOW (90 dB) or HI (100 dB).

Using the Hold Function

The Hold function enables you to remove the patient from a bed or chair without activating the alarm system. To enter Hold Mode, press the Hold/Reset button on the Patient Unit for one second. The unit will beep twice and the yellow Hold LED will begin flashing to confirm that the unit is in Hold Mode. The unit will beep twice when Hold mode has expired.

The duration of Hold Mode is determined by the user-specified Hold Length setting, and can be set to 5, 15, 30, or 60 seconds. For more information on changing the Hold Length option, refer to the *Programming* section of this manual.

Extending Hold Mode

When the unit is in Hold Mode, you can press the Hold/Reset button again to extend Hold mode. The unit beeps once to indicate that Hold mode is extended. You can extend Hold mode an unlimited number of times.

Example: The Hold Length setting is set to 30 seconds. Nurses enter the room to remove the patient from bed and press the Hold/Reset button. At 15 seconds, they realize they need more time and press the Hold/Reset button again. They now have 30 seconds from the moment they pressed the Hold/Reset button a second time to remove the patient from bed without activating the alarm.

Patient Unit DIP Panel

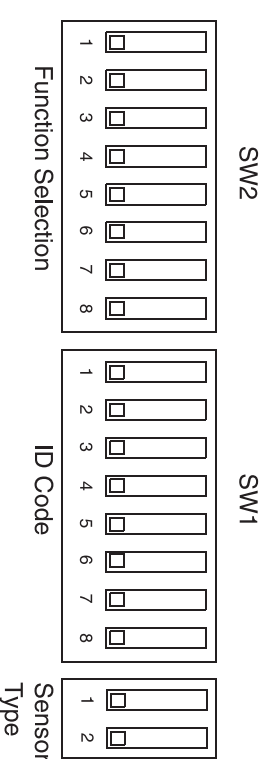

Remote Unit DIP Panel

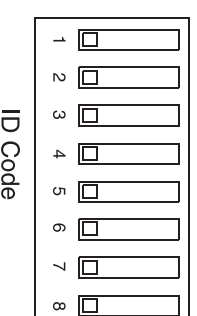

WARNING! - Static electricity can cause significant damage to circuit boards. Before attempting to program a DIP Panel, make sure you eliminate any static charge by touching a metal surface (for example, a file cabinet or metal chair).

On the Remote Unit, the only DIP option is assigning an ID Code. Assigning an ID code enables you to determine which Patient Unit communicates with the Remote Unit.

IMPORTANT: In order for the Remote Unit and Patient Unit to work together, you must assign the same ID Code to both units. Also, when using multiple Wireless Sensor Systems in close proximity to one another (for example, two systems within a two-patient room), make sure the ID Codes for each system is different. If desired, you can assign multiple Patient Units to signal a single Remote Unit, or assign multiple Remote Units to a single Patient Unit.

Patient Unit Programming Options

Function	Default Setting	Available Settings
Alarm Volume	Low (90 dB)	Low (90 dB) High (100 dB) Silent
Hold Length	5 seconds	5 seconds 15 seconds 30 seconds 60 seconds
Activation Delay	0 seconds	0 seconds 2 seconds 4 seconds
Alarm Length	Continuous	Continuous 15 seconds 30 seconds 60 seconds
ID Code	All Switches Off	You can specify up to 256 separate ID codes.
Sensor Type	Bed/Chair	Bed/Chair Floor Optical

Mode	Sensor Type	Description
Hdd	All	System ignores all activity. This mode should be used in place of powering down the unit when attending to the patient. When Hold mode expires, system automatically returns to Monitor mode.
Full Reset	Bed/Chair	System resets when weight is re-applied to the sensor pad or when Hold/Reset button is pressed on Patient Unit.
Semi-Reset	Floor/Optical	System resets when Hold/Reset button is pressed on Patient Unit.
Semi-Reset	All	Alarm Silence button has been pressed on Remote Unit. Alarm tone stops sounding. The yellow light panel flashes slowly to indicate Semi-Reset Mode. If the system is not fully reset within 5 minutes, the Remote Unit will begin sounding tone and flashing the yellow light panel to notify staff that the system has not been fully reset.

Turning the Power On/Off

Patient Unit

Press and hold the Power button on side of unit for 1.5 seconds. Green LED will light up and unit will beep twice to indicate power is on.

Turn power off before changing sensor setting.

Remote Unit

Slide the Power switch on side of unit to ON. Yellow light panel on front of unit will flash and unit will beep twice to indicate power is on.

When the Wireless Sensor System is activated, the Patient Unit emits an audible alarm (if programmed) and sends a signal to the Remote Unit to also sound an alarm. Once hearing the alarm, the caregiver can immediately attend to the patient.

System Modes

The following table gives a brief description of each system mode:

<i>Mode</i>	<i>Sensor Type</i>	<i>Description</i>
System Ready	Bed/Chair	Sensor pad is plugged into the patient unit but no weight has been placed on the sensor pad. Unit can be left in System Ready mode for extended periods. Unit will automatically enter Monitor mode the next time weight is detected on the sensor pad.
	Floor/Optical	5 second delay period immediately following power on or system reset.
Monitor	Bed/Chair	Weight is on the sensor pad. Removal of weight during this period will activate the system.
	Floor/Optical	Period after the 5 second delay in System Ready mode. No weight on the floor pad or motion in the sensor beam. Any weight on the floor pad or motion in the sensor beam will immediately activate the system.
Activated	Bed/Chair	Weight has been removed from the sensor pad and unit is alarming.
	Floor/Optical	Weight was detected on the floor pad or motion detected by the optical sensor and unit is alarming.

Assigning Sensor Types

The Assign Sensor Type function enables you to specify which type of sensor (Bed/Chair, Floor, or Optical) you are going to connect to the Patient Unit.

The following figure shows the DIP settings for each sensor type. To assign a sensor type, program the Sensor Type DIP Panel to correspond with the appropriate sensor type.

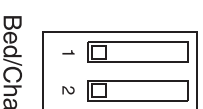

Bed/Chair

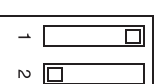

Floor

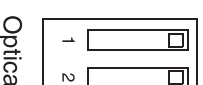

Optical

IMPORTANT: Attach Bed/Chair sensor pads to Jack # **1 only**. The system will not function if Bed/Chair sensor pads are attached to Jack # 2. Floor and Optical sensors can use either jack.

When using Bed/Chair sensors, you can only attach one Bed/Chair sensor to the Patient Unit. You cannot attach a second Bed/Chair sensor or combine a Bed/Chair sensor with Floor or Optical sensors.

When using Floor or Optical sensors, you can attach 2 sensors to the Patient Unit. You can connect 2 Floor sensors, 2 Optical sensors, or one of each.

Turn power off before changing sensor setting.

Assigning ID Codes

In order for the Patient Unit and Remote Unit to communicate, **you must assign the same ID Code to both units**. If the ID Codes do not match, the Remote Unit will not receive any signals from the Patient Unit. If desired, you can assign multiple Patient Units to signal a single Remote Unit, or assign multiple Remote Units to a single Patient Unit.

To assign ID Codes, refer to the following example:

Example: You want to assign the following ID Code to the Remote Unit and Patient Unit:

DIP Switch #	Position
1	DOWN
2	UP
3	DOWN
4	DOWN
5	UP
6	UP
7	DOWN
8	UP

Tip: You may want to refer to the ID Code as a number to make it easier to identify. To do so, simply refer to the number of each switch that is in the UP position. In this example, the number for the ID Code would be 2568.

To assign the ID Code 2568 to the Patient and Remote Units, program the DIP panels as shown in the following figure:

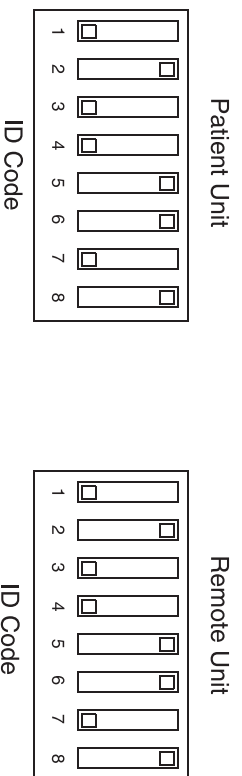

Operation

Overview

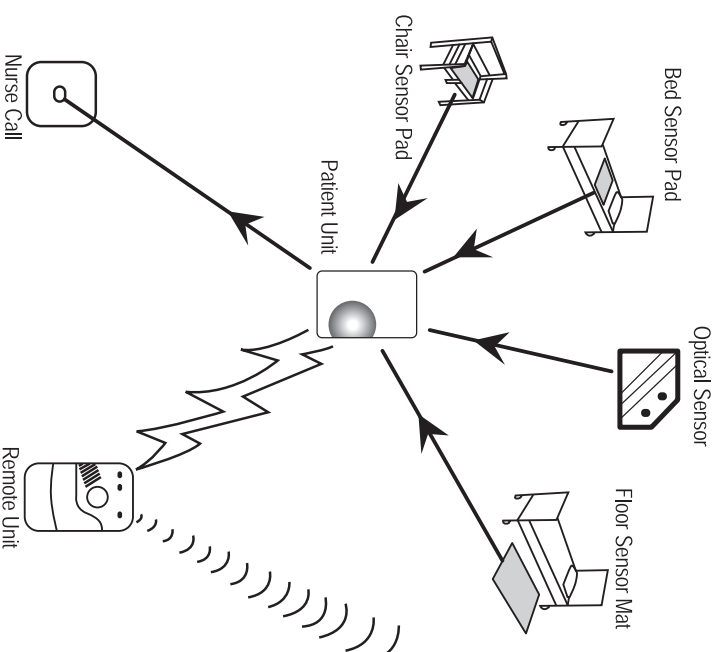

The system activates when one of the following situations occurs:

- Weight is removed from the sensor pad.
- Weight is detected on the floor mat or motion is detected by the optical sensor (either a momentary detection or a continuous presence).

Alarm Length

The Alarm Length function enables you to specify how long the Patient Unit alarm sounds once it is activated. The following figure shows the Function Selection DIP settings for the Alarm Length option.

NOTE: The Alarm Length option does not affect the Remote Unit.

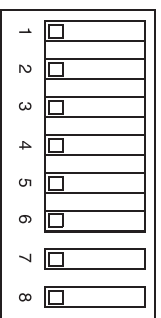

Continuous

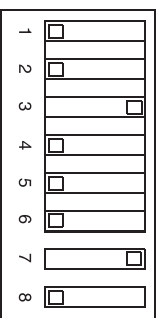

15 seconds

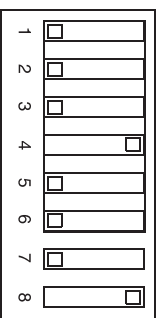

30 seconds

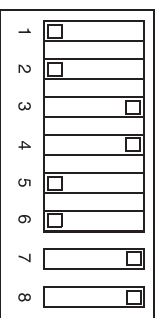

60 seconds

Alarm Volume

This option enables you to set the Patient Unit Alarm Volume as Low (90 dB), High (100 dB), or Silent. To set the Alarm Volume, use the figure below to program the Function Selection DIP panel with the desired setting.

NOTE: Selecting Silent affects the Patient Unit alarm only. Sounds to confirm other actions (for example, power on, Hold mode, etc.) will still be audible. Also, the Remote Unit will sound if the alarm is activated.

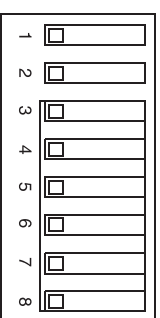

Low Volume (90 dB)

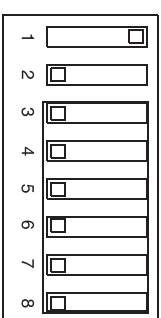

High Volume (100 dB)

OR

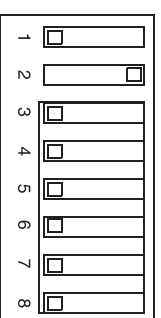

Silent

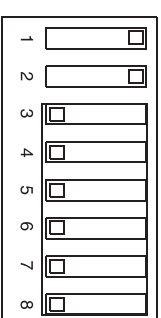

Hold Length

The Hold Length function enables you to specify how long the system remains in Hold Mode when the Hold/Reset Button is pressed on the Patient Unit. The following figure shows the Function Selection DIP settings for the Hold Length option.

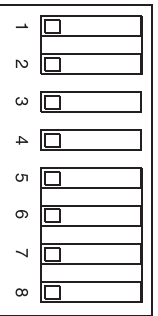

5 seconds

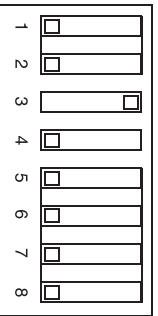

15 seconds

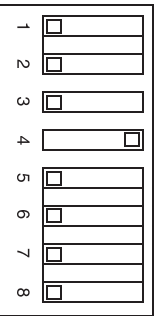

30 seconds

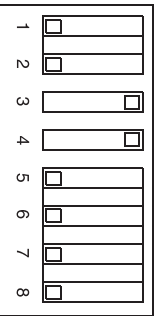

60 seconds

Activation Delay

The Activation Delay option enables you to set how long the system waits before sounding an alarm. For example, you may want to set a delay of 4 seconds for a patient who moves frequently in bed. **This setting applies to the Bed/Chair sensor type only and is not available for Floor or Optical sensors.**

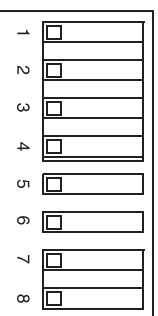

0 seconds

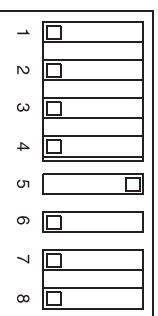

OR

2 seconds

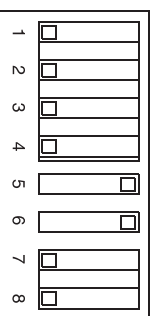
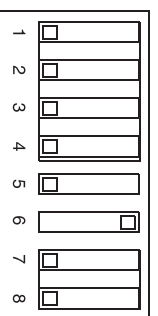

4 seconds